

BRUNETTE UNI-LOG FEEDER

FULLY AUTOMATIC SINGLE LOG FEEDER

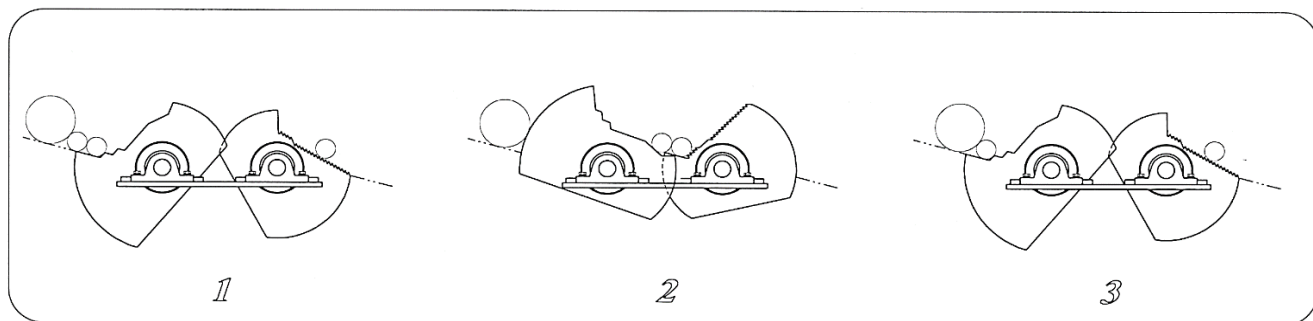
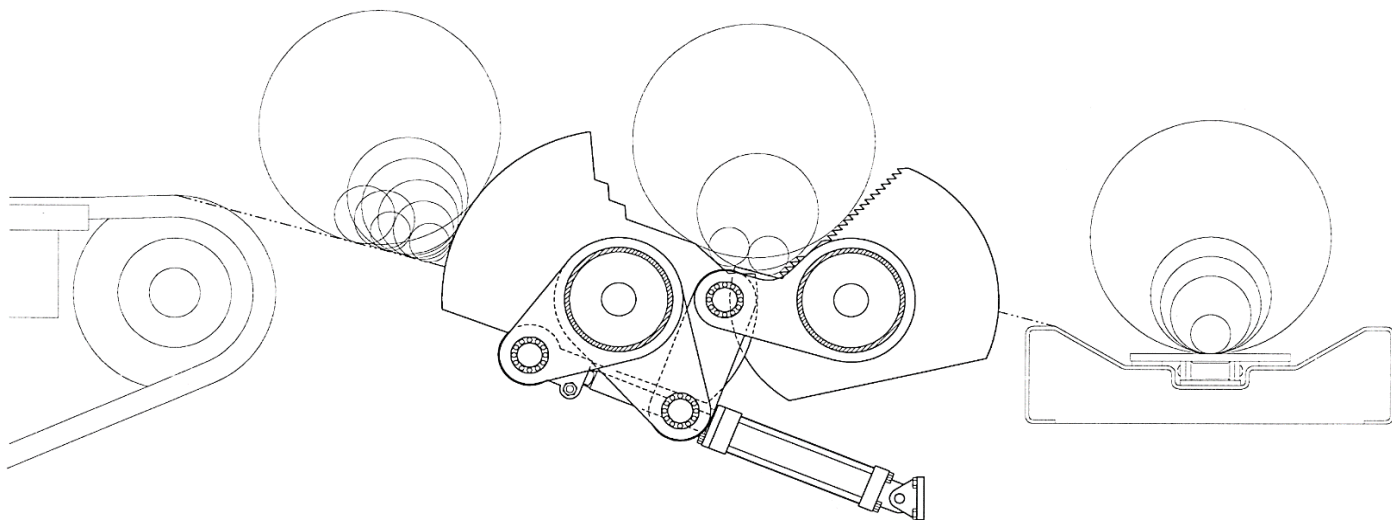

The Brunette fully automatic, high speed UNI-LOG FEEDER delivers top productivity for your mill's high-tech future.

The Brunette Log Feeder offers such profitability enhancing features as:

- Simple robust design.
- AutoCAD computer engineered components.
- Easily retro-fitted into existing log handling systems.
- Optional pneumatic or hydraulic operation.
- Singulates and feeds logs one at a time from 8ft to tree length.
- Choose from 3-18", 4-24", 5-30" or 6-36" models.



Brunette Machinery Co.
Head Office / Capital Sales
8717 132nd Street
Surrey, BC
Canada V3W 4P1
Phone: 604-522-3977
Fax: 604-522-6806
Email: sales@brunettemc.com

Brunette Machinery Co.
Northern BC Division
1076 Great Street
Prince George, BC
Canada V2N 2K8
Phone: 250-563-0596
Fax: 250-563-8179
Email: pgooffice@brunettemc.com