

# Brunette CHIPPER MAINTENANCE BRAKE UPGRADE

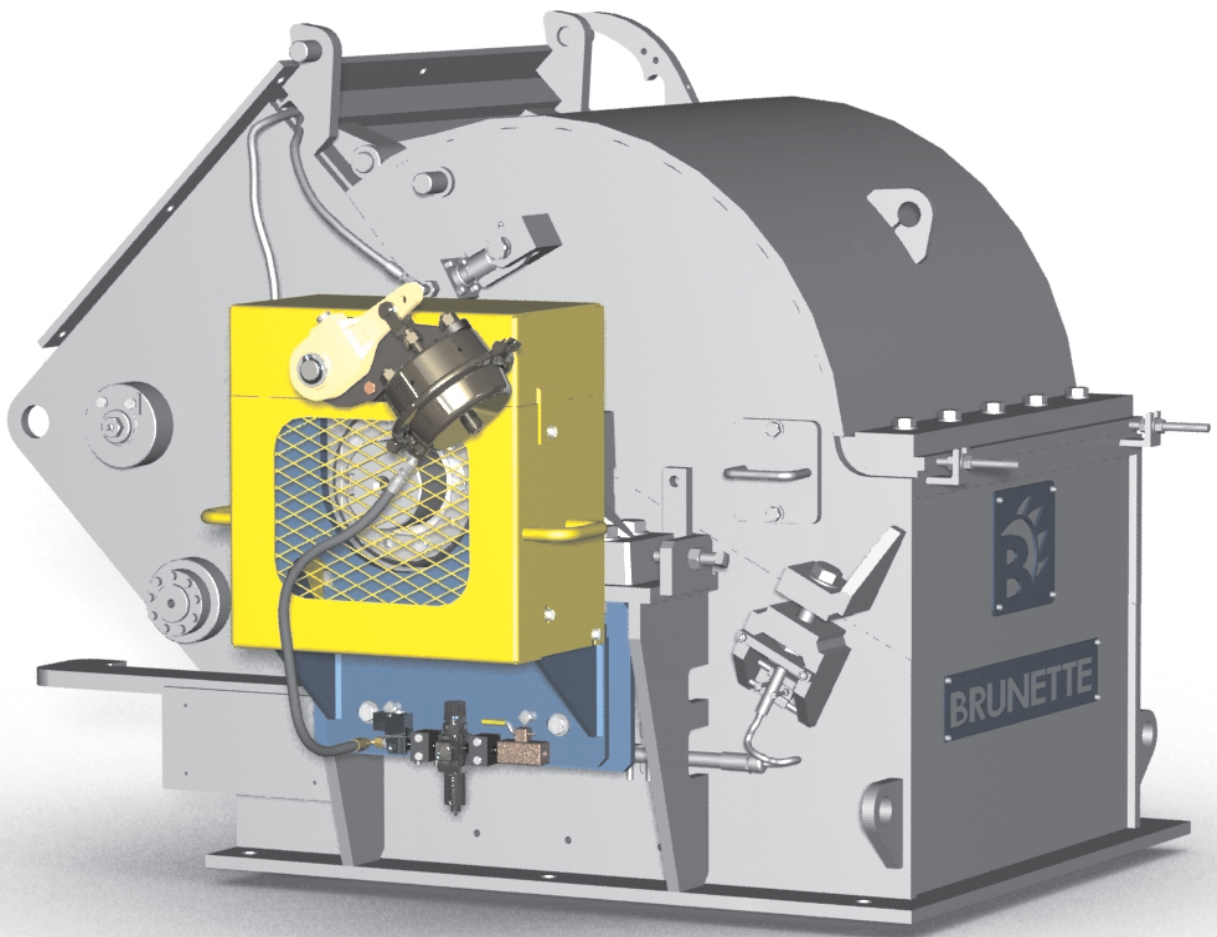

***“give your maintenance budget a brake”***

# Brunette CHIPPER MAINTENANCE BRAKE UPGRADE

- upgrade your drum chipper
- easy field retrofit
- less maintenance downtime for quicker knife changes by minimizing rotor stop time
- pulsating air supply controlled by customer plc
- complete with installation drawing
- installation available

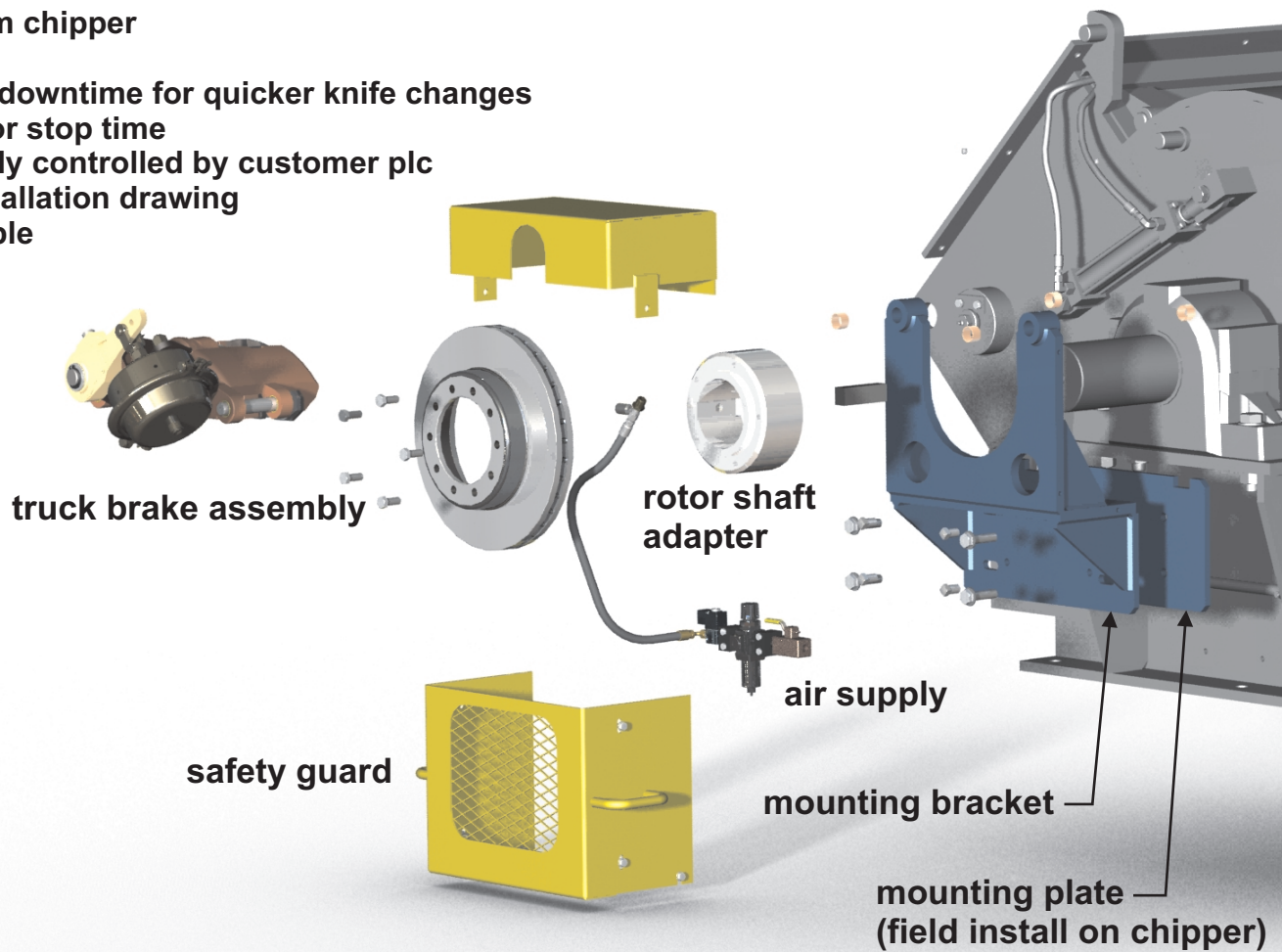

for more information contact: **sonia prost, parts and service**  
phone: 604-522-3977, email: **sonia@brunetteindustries.com**